

11. TV Orientation

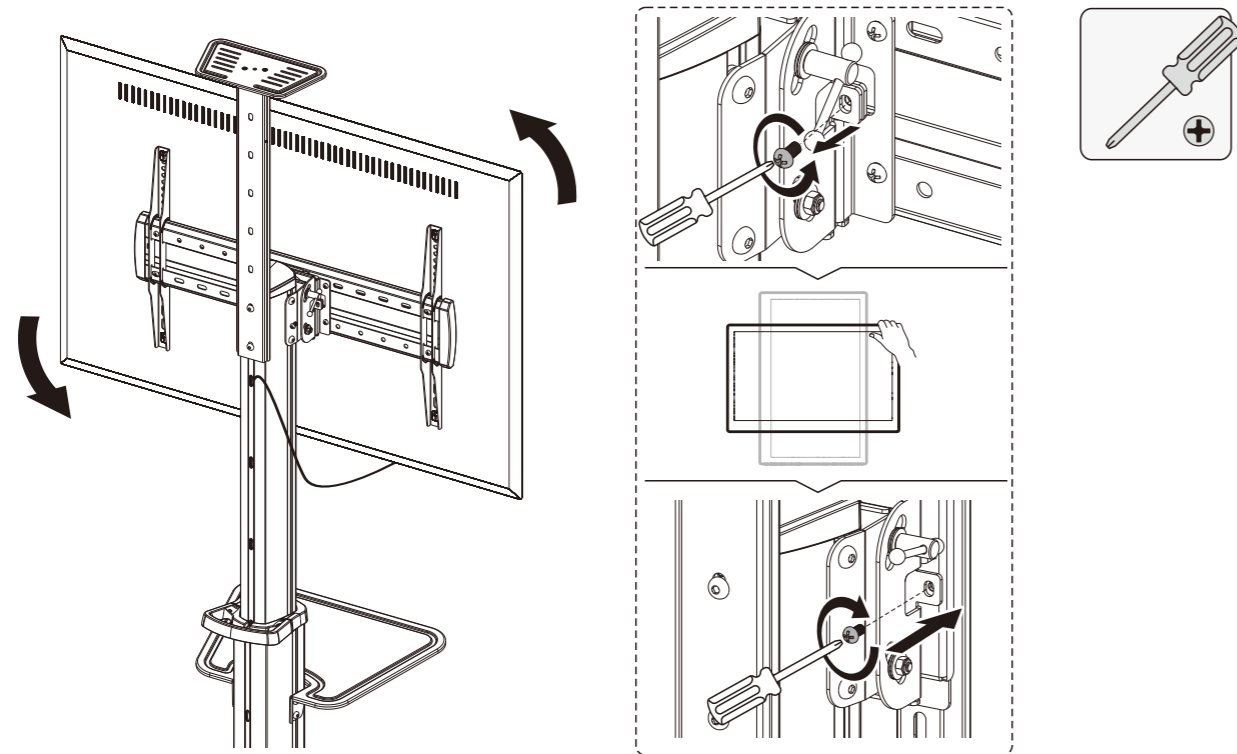

12. Adjustment

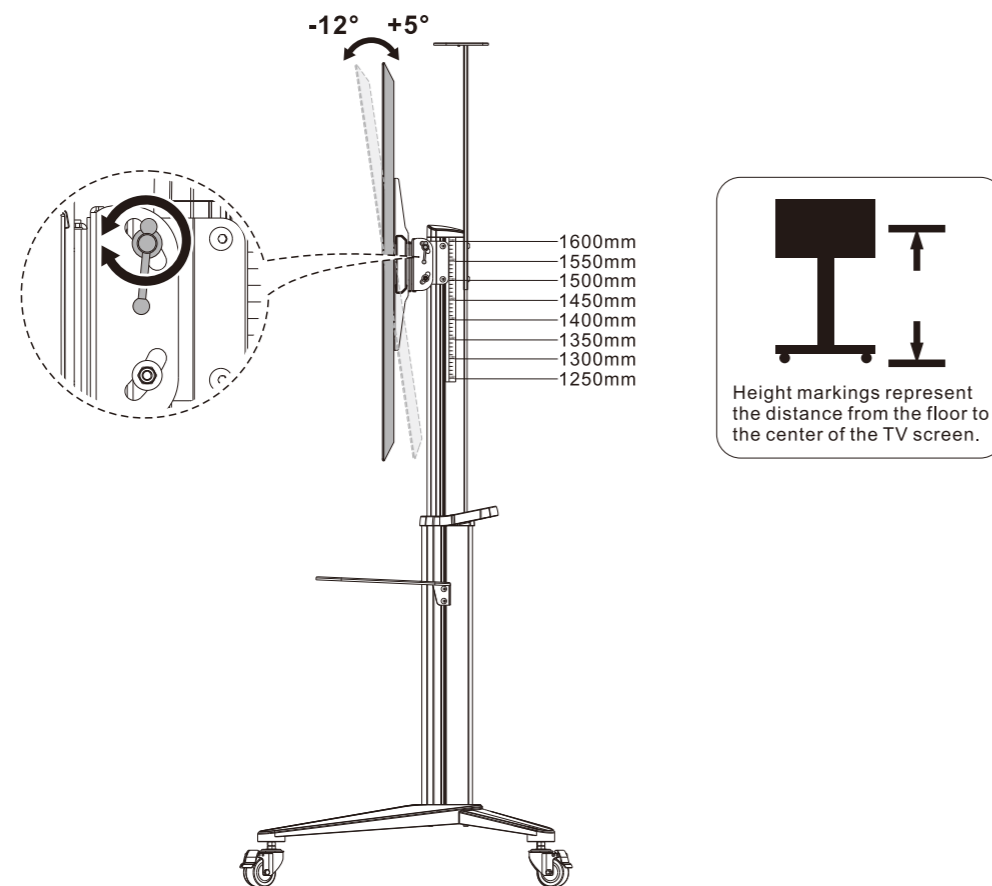

Maintenance

- Check if the bracket is secure and safe to use at regular intervals (at least every three months).
- Please contact your distributor if you have any questions.

goods^{for}
BUSINESS
goodsforbusiness.de

TV Cart

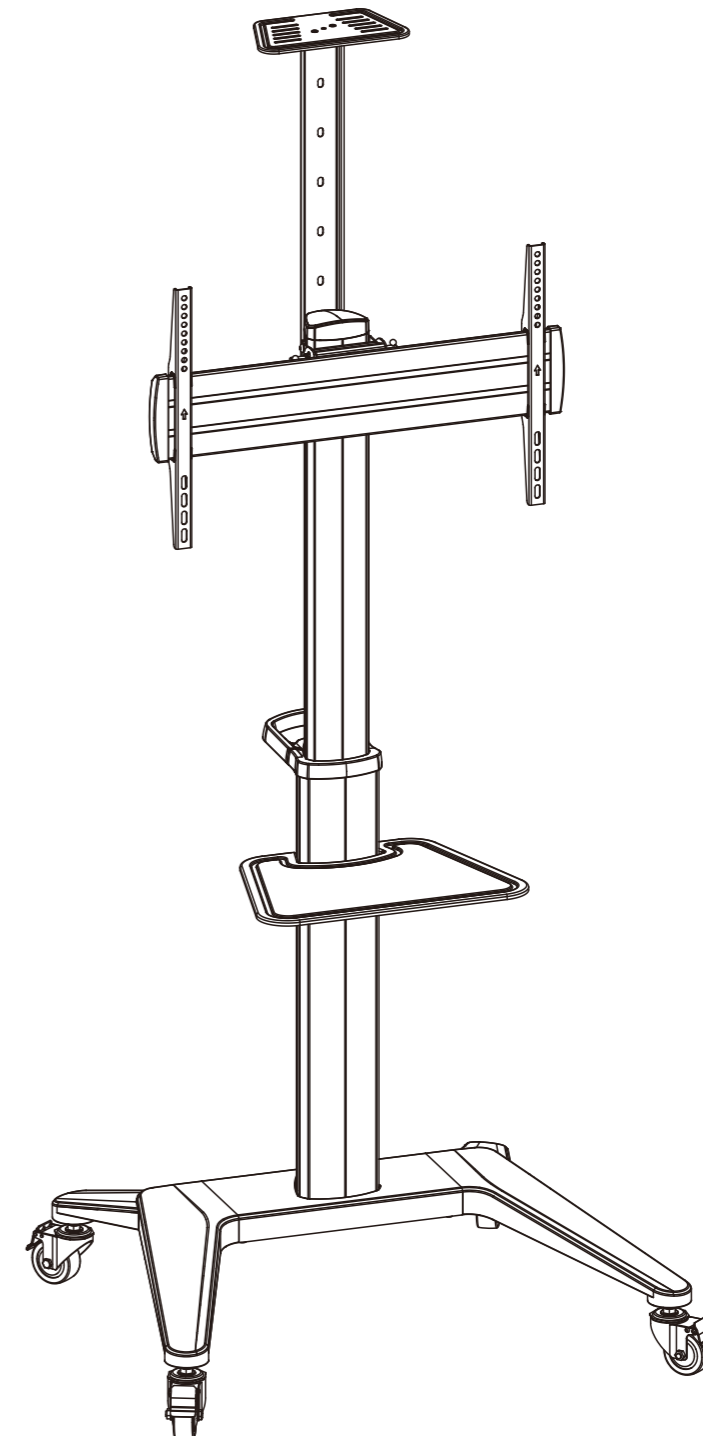

goodsforbusiness GmbH
Wierlings Busch 75
48249 Dülmen

INSTALLATION MANUAL

83775

VESA Compatible
200x200/300x200
300x300/400x200
400x300/400x400
600x400

70"
MAX

rated
for TV

rated
for DVD

rated
for CAMERA

70kg/154lbs 5kg/11lbs 5kg/11lbs

 **Read the entire instruction manual before you start installation and assembly. If you have any questions regarding any of the instructions or warnings, please contact your local distributor for assistance.**

CAUTION

- Use with products heavier than the rated weights indicated may result in instability causing possible injury.
- Please closely follow the assembly instructions. Improper installation may result in damage or serious personal injury.
- Safety gear and proper tools must be used. This product should only be installed by professionals.
- Make sure that the supporting surface will safely support the combined weight of the equipment and all attached hardware and components.
- Use the mounting screws provided and **DO NOT OVER TIGHTEN** mounting screws.
- This product contains small items that could be a choking hazard if swallowed. Keep these items away from children.
- This product is intended for indoor use only. Using this product outdoors could lead to product failure and personal injury.

Requirement for Installation



Component Checklist

IMPORTANT: Ensure that you have received all parts according to the component checklist prior to installation. If any parts are missing or faulty, contact your place of purchase for a replacement.

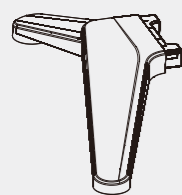

left leg
A (x1)

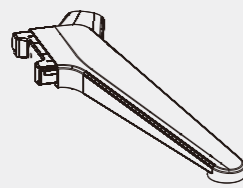

right leg
B (x1)



cross bracket
C (x1)



caster
D (x4)



lower column
E (x1)



upper column
F (x1)



AV equipment shelf
G (x1)

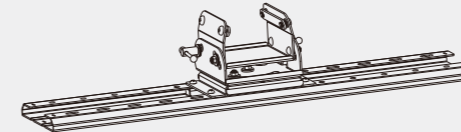

mounting plate assembly
H (x1)

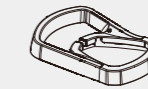

handle
I (x1)



TV bracket
J (x2)



connecting bracket
K (x1)



camera shelf
L (x1)



end cap
M (x2)



top cover
N (x1)



cable cover
O (x8)

Package P



washer
P-A (x4)

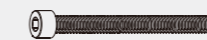

M8x80
P-B (x4)



M8x20
P-C (x12)



M6x12
P-D (x4)



M5x8
P-E (x2)



M6 wrench
P-F (x1)

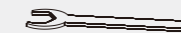

M12 wrench
P-G (x1)



5mm Allen key
P-H (x1)

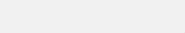

6mm Allen key
P-I (x1)

Package M



M5x14
M-A (x4)



M6x14
M-B (x4)



M6x30
M-C (x4)

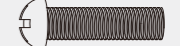

M8x30
M-D (x4)

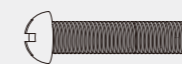

M8x50
M-E (x4)



washer
M-F (x4)



small spacer
M-G (x8)



big spacer
M-H (x8)

1. Assemble the Base

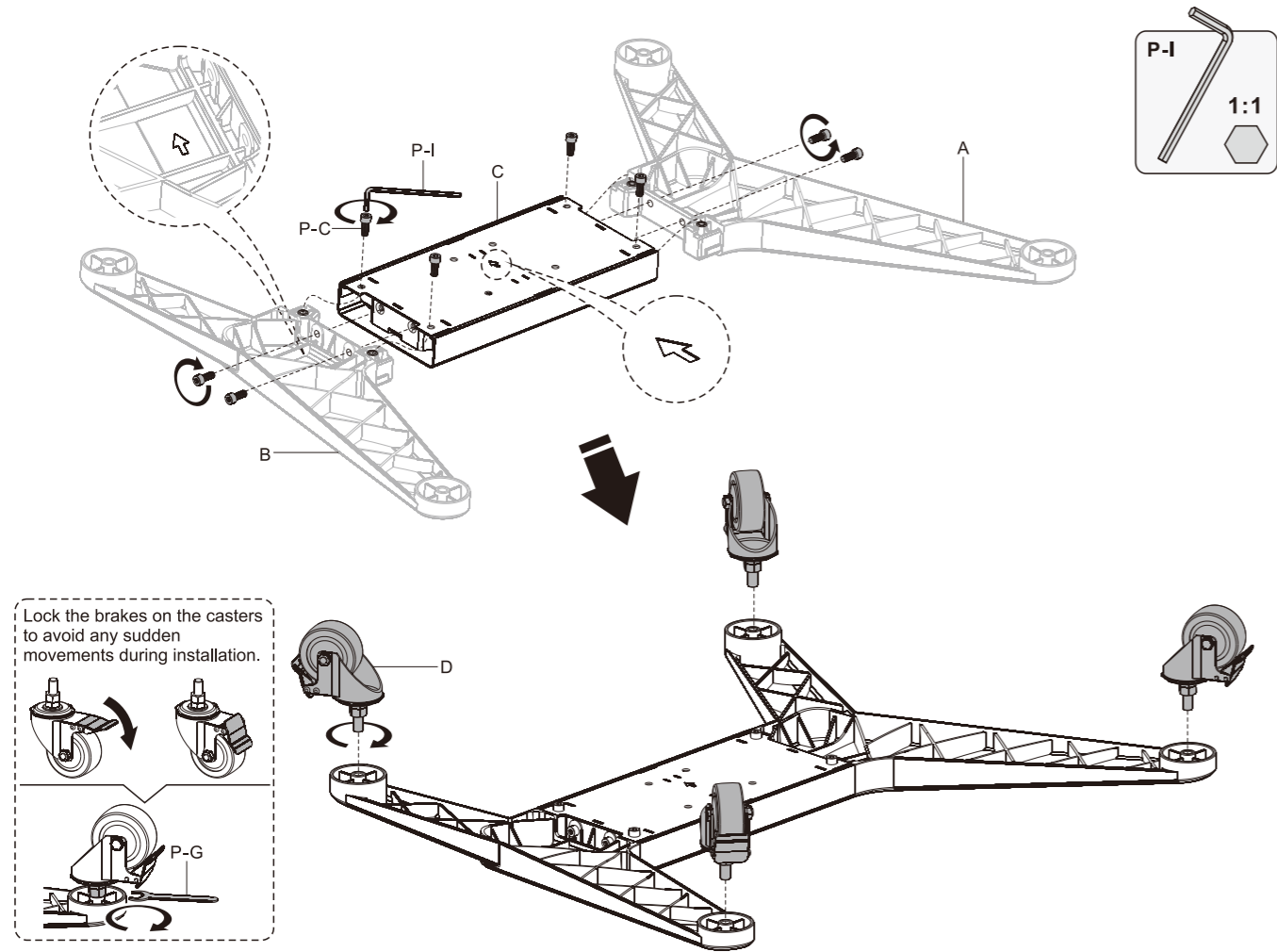

2. Assemble the Columns

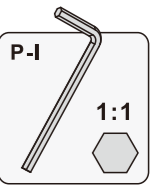
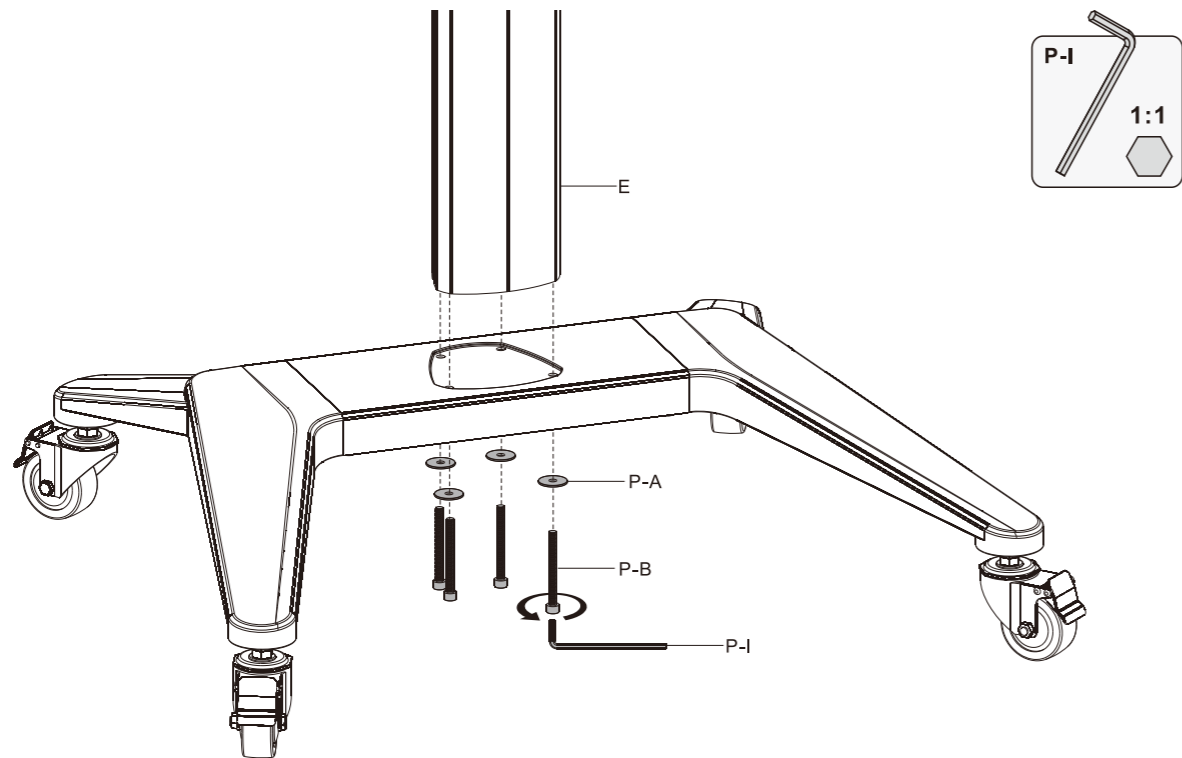

3. Assemble the AV Equipment Shelf

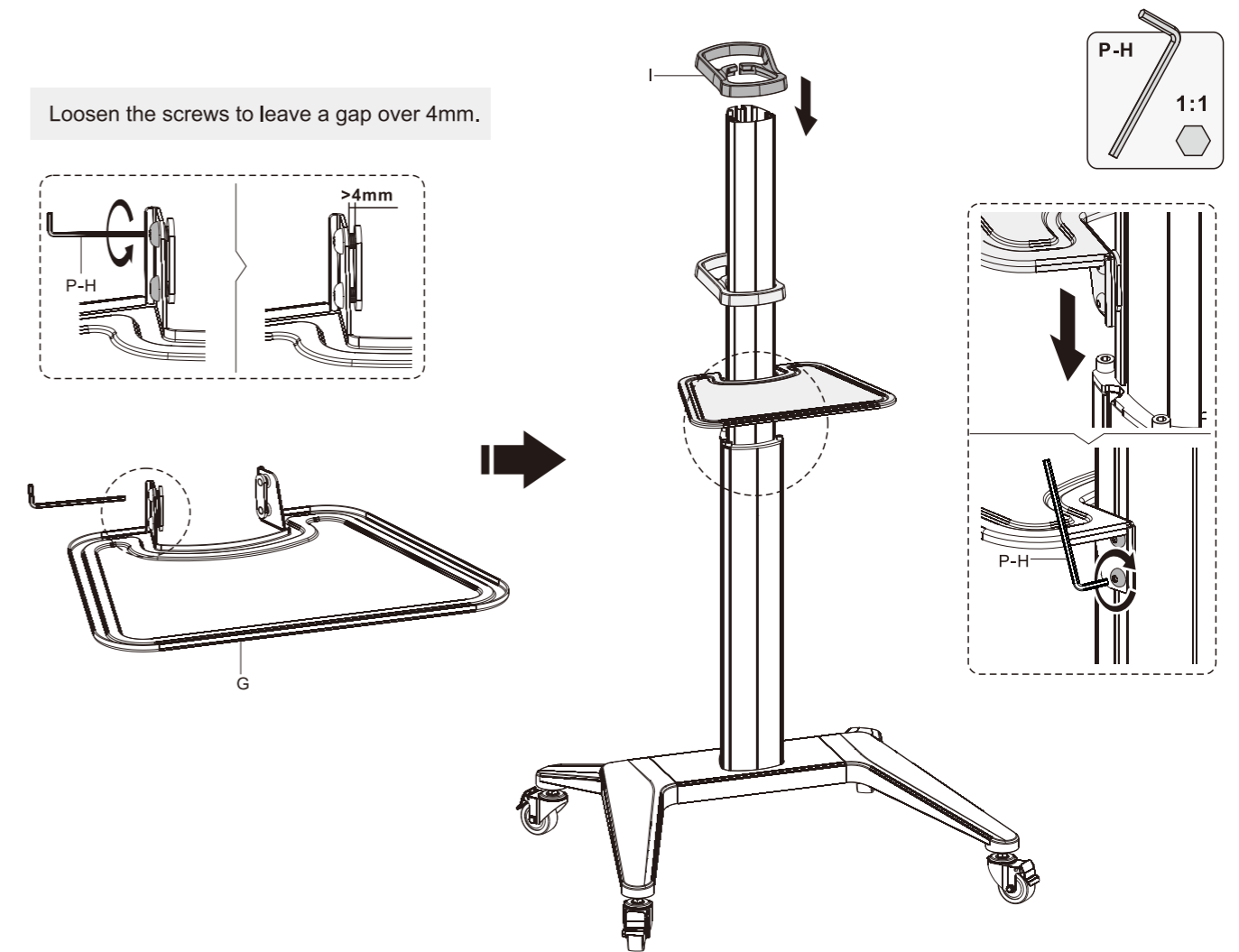

4. Attach the Connector to the Column

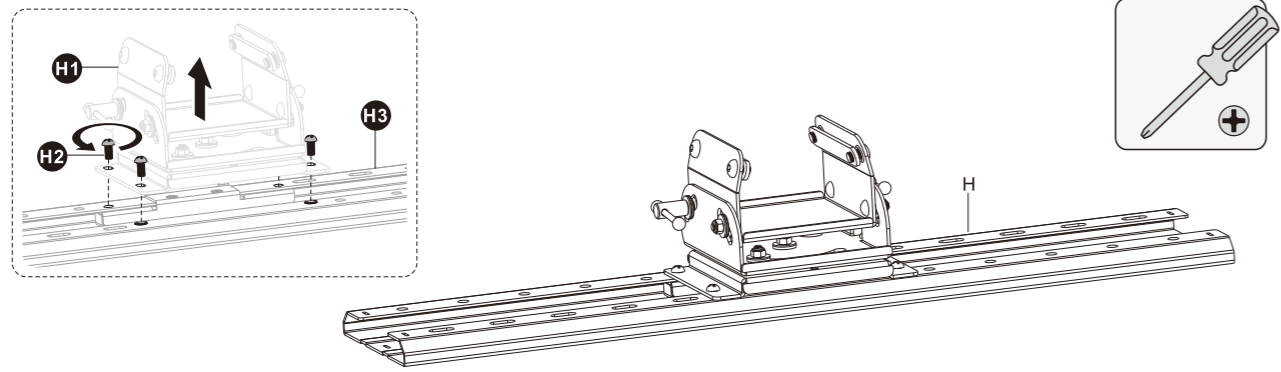

Loosen the screws to leave a gap over 4mm.

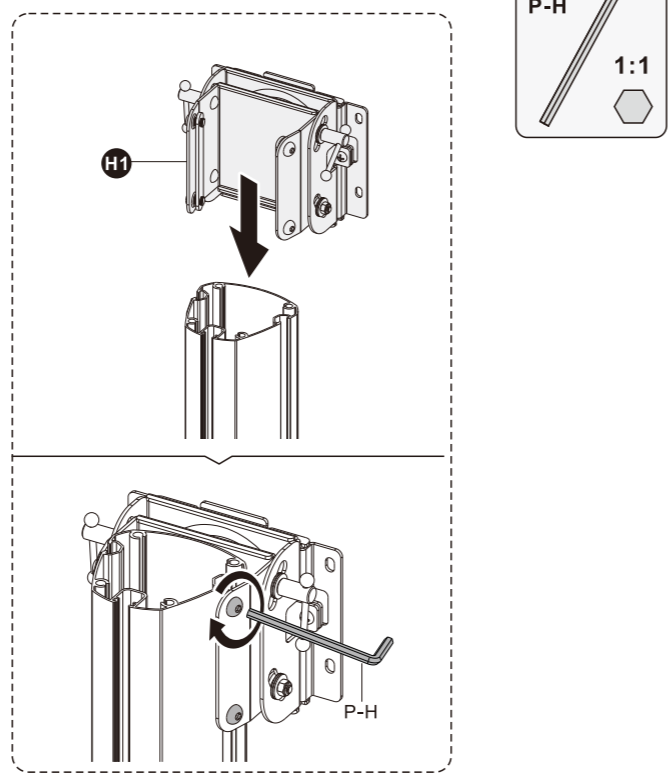
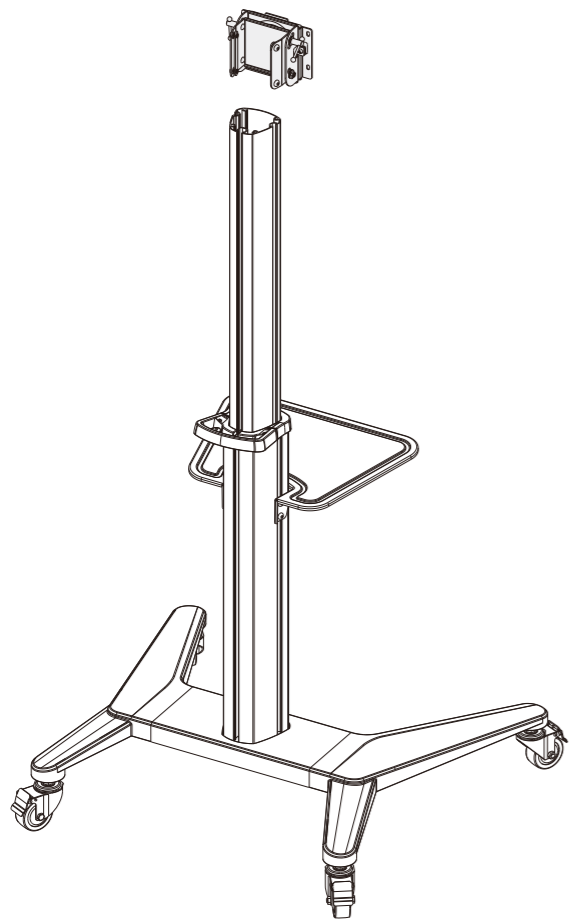
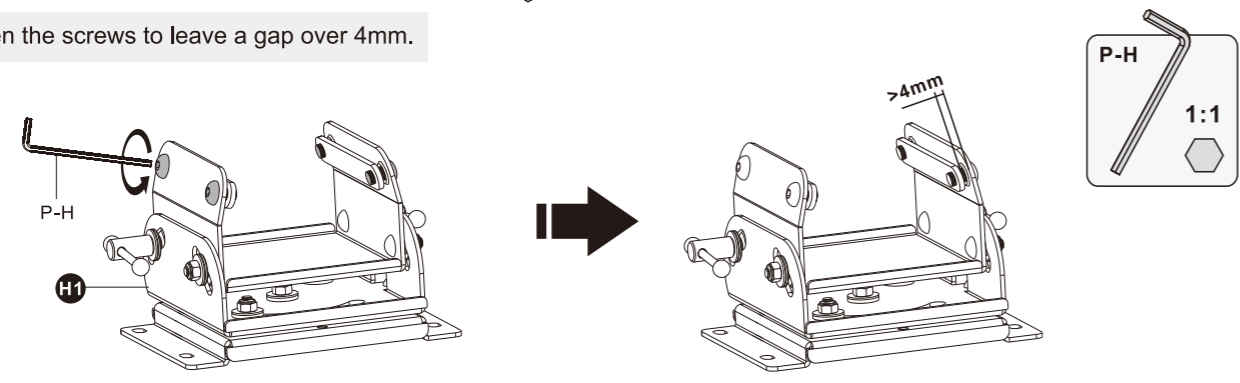

5. Attach TV Bracket to the Mounting Plate

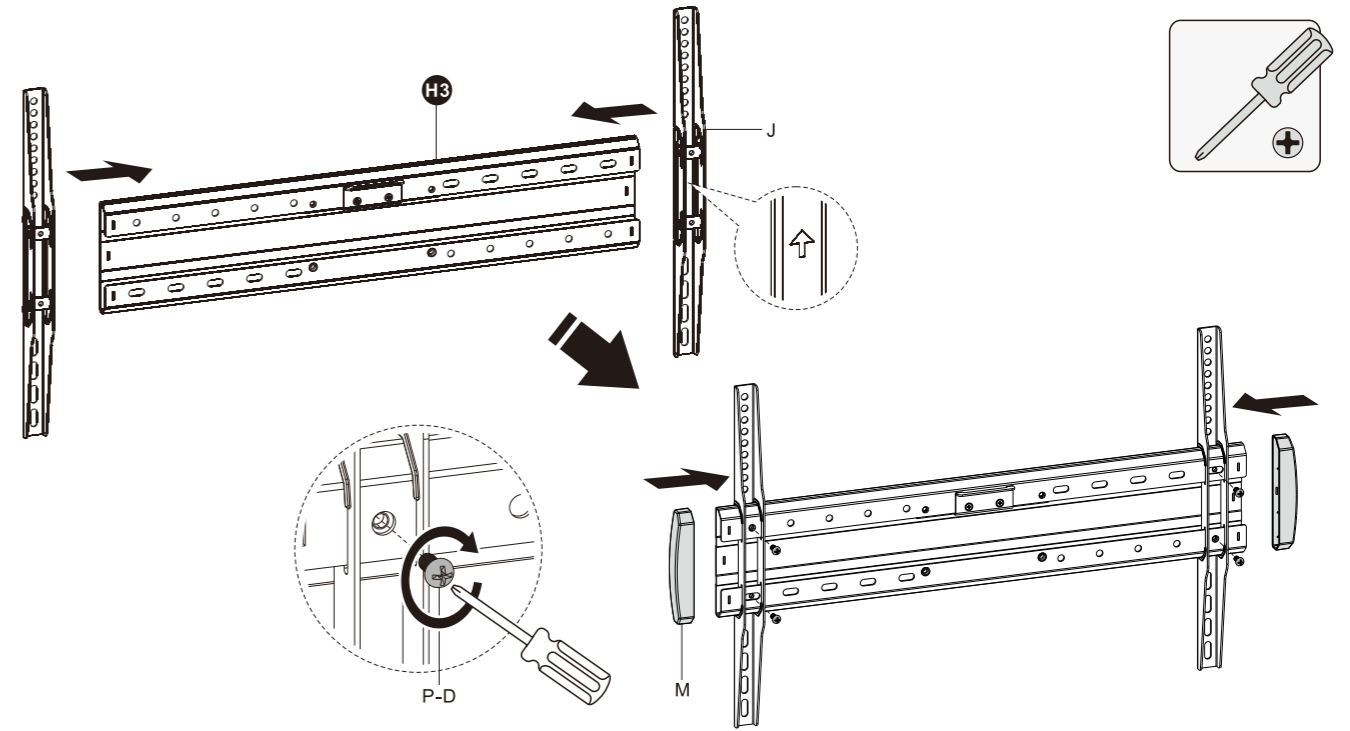

6a. Attach TV Bracket to Flat Back Screen

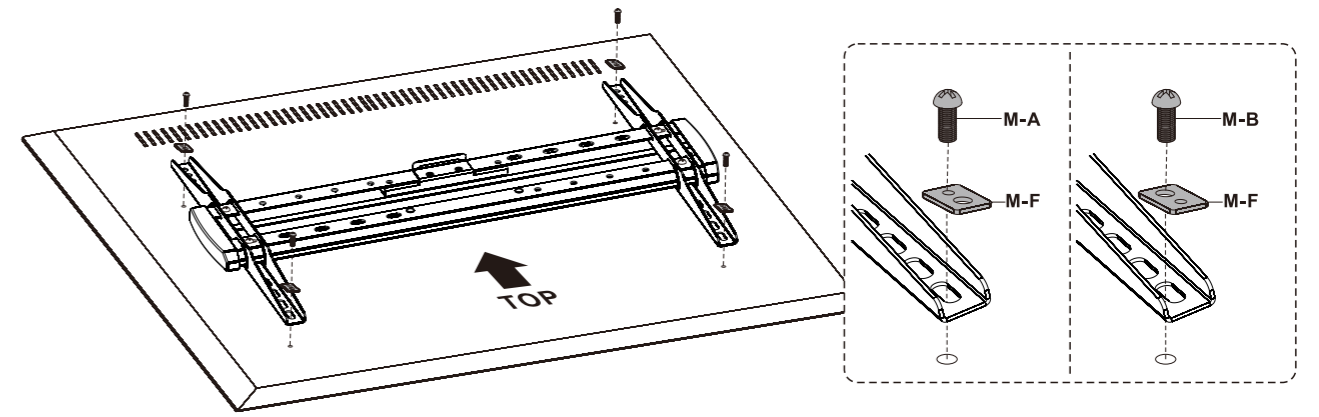

M-A			M-B		
M-F			1:1		

6b. Attach TV Bracket to Irregular Back Screen

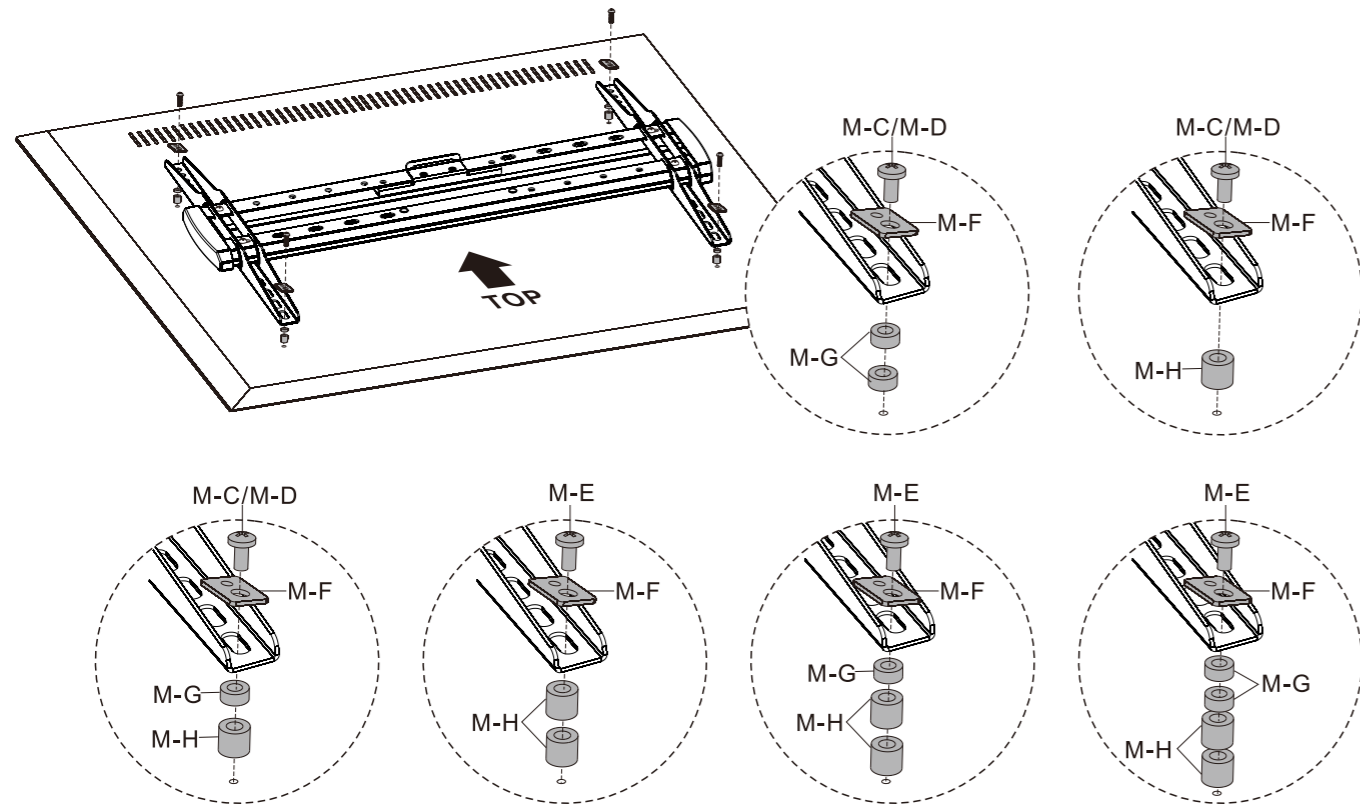
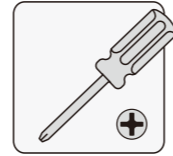
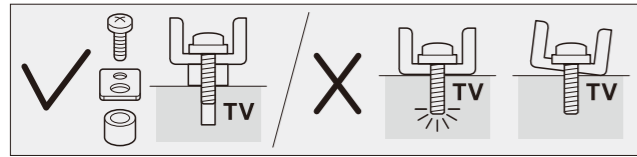

M-C		M-D	
M-E		M-F	
M-G		M-H	

1:1

7. Hang and Secure the Screen

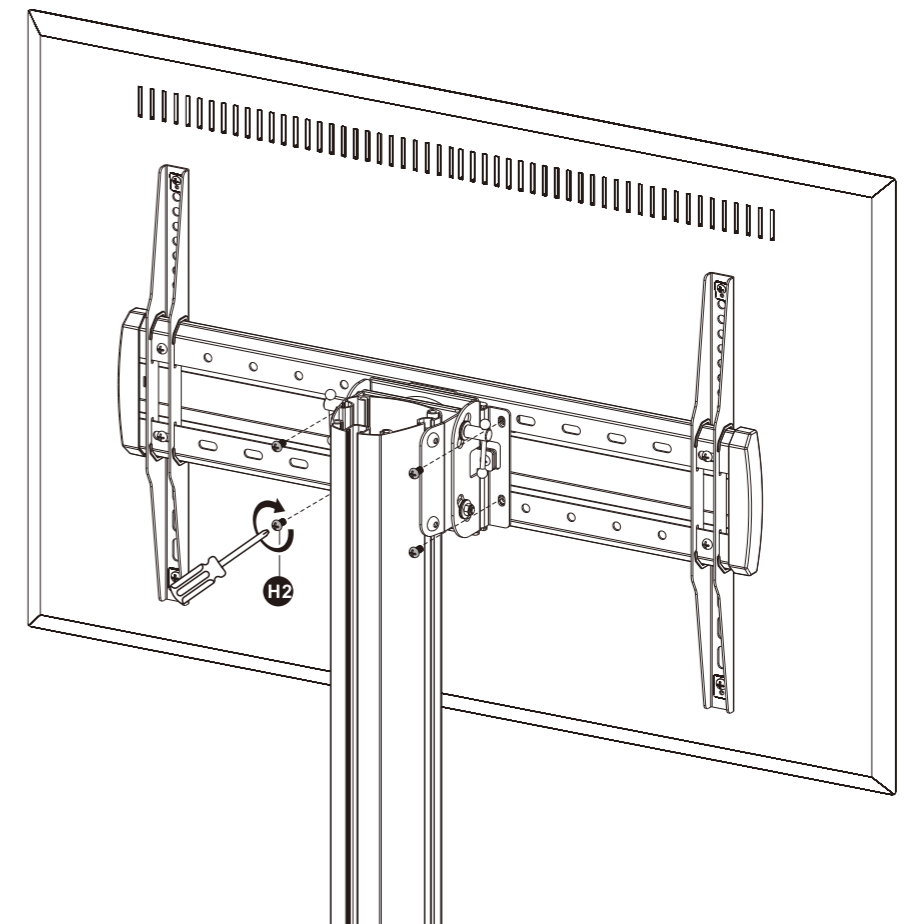
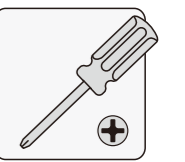
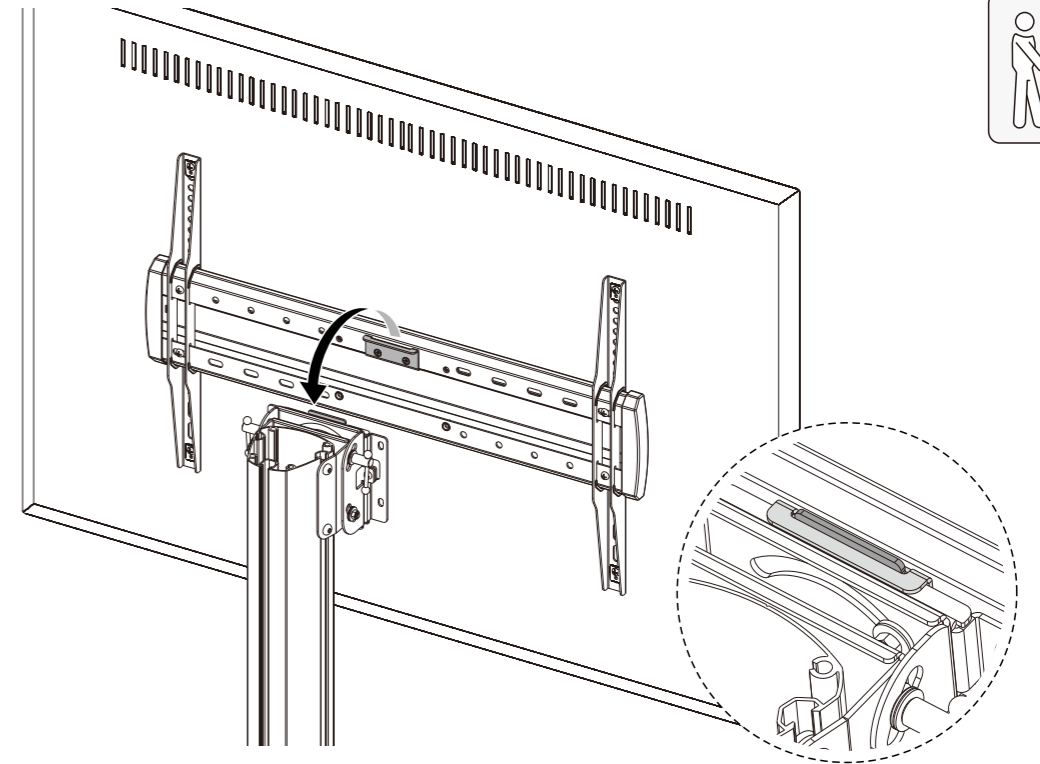
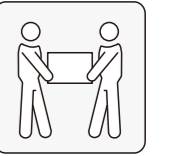

8. Assemble the Camera Shelf

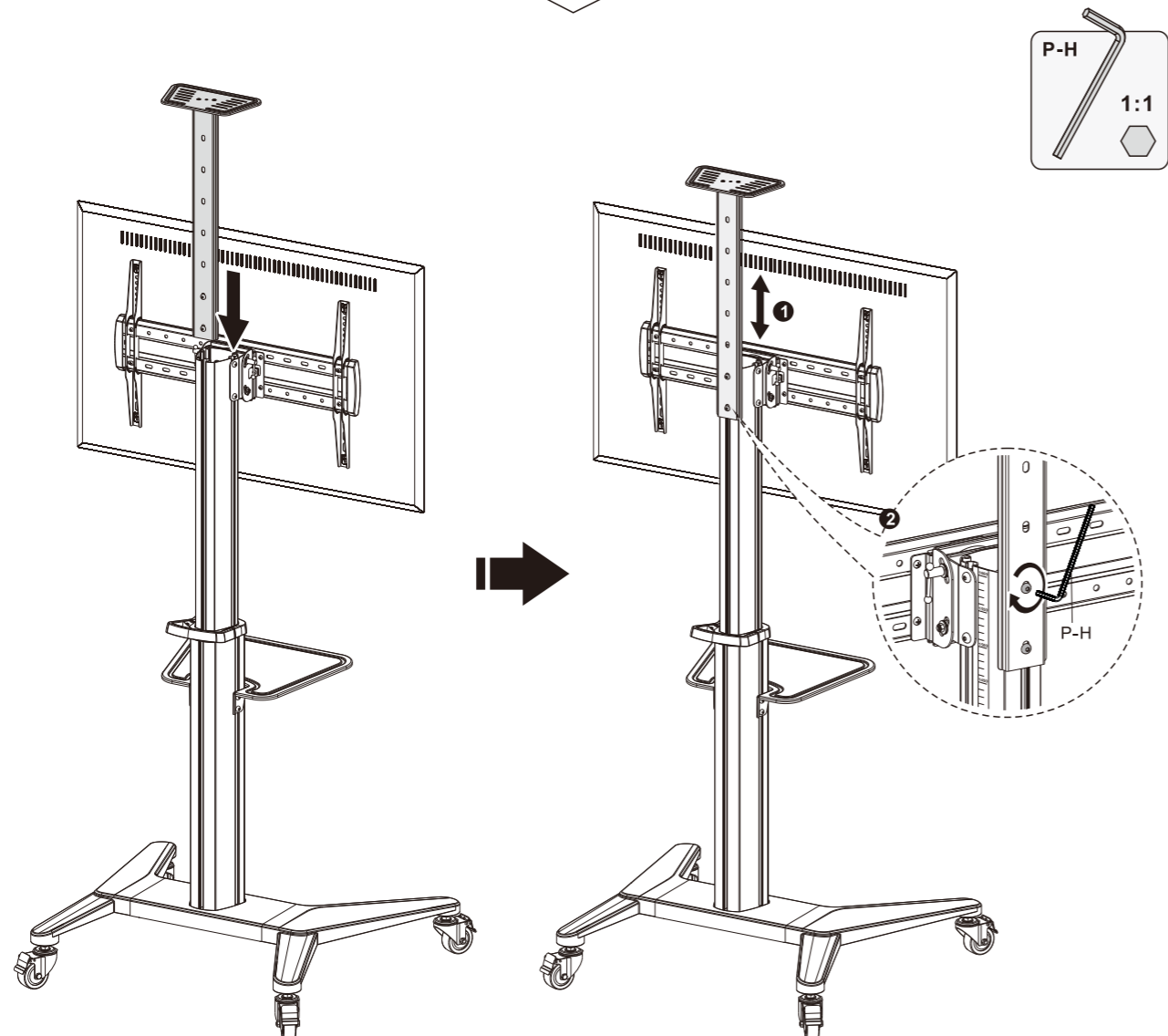
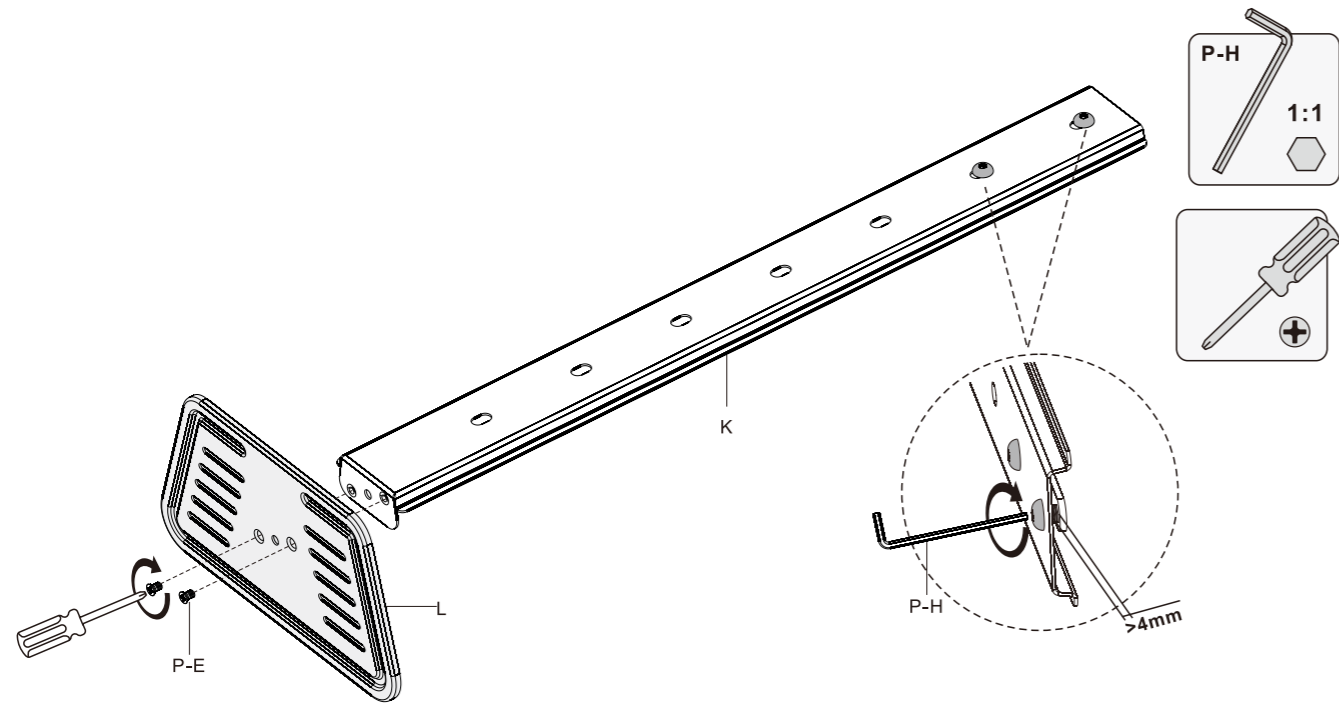

9. Assemble the Top Cover

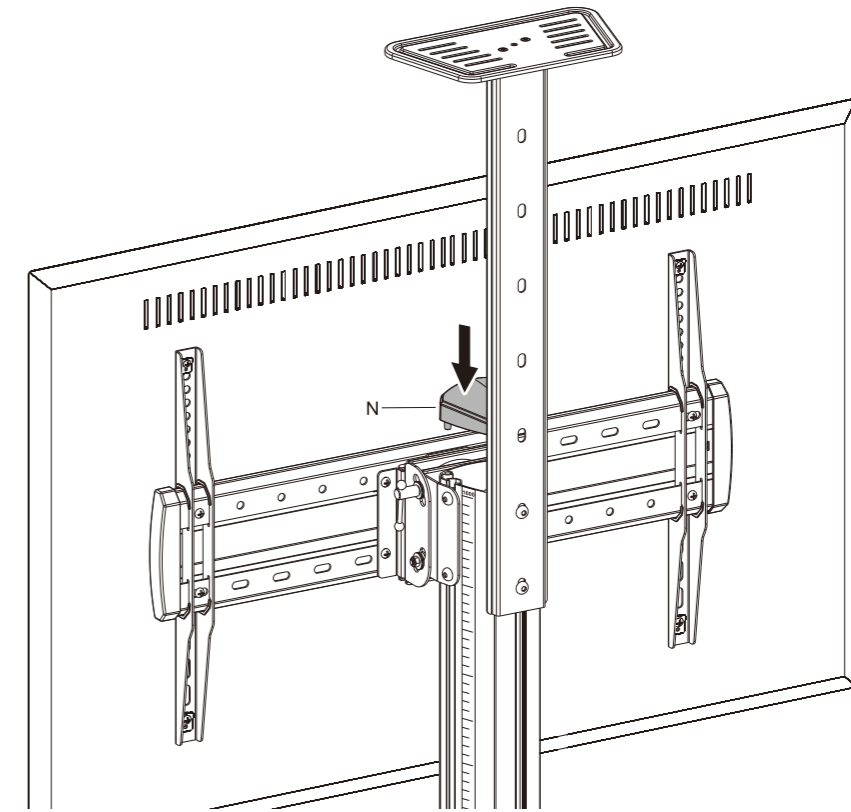

10. Cable Management

